

Ring SIA

INDUCTIVE RING SENSORS



GENERAL CHARACTERISTICS

In ring sensors, sensing is made within the ring itself. The sensor is activated when a metallic object is introduced within it.

They are particularly suitable for applications where detection of small metal objects such as screws, nuts, washers etc... is requested and also for break detection of continuous metal wires that pass through it. The sensor's housing is made of plastic and the electrical attachments are available by means of a cable or M8 and M12 connectors depending on the models.

They are supplied with fixed timing impulse (100mS) insertable by means of an ON/OFF switch, that makes them ideal for detection of fast moving small metal objects.

They are available with internal diameter of 5-12-15-22-25-30-44-63-100 mm and supplied with NPN or PNP output, sensibility regulation, insertion/disinsertion of impulse retention time and LED state of condition.

All ring sensors have antivalent output (NO+NC) except for the types with H1 connectors.

SELECTION OF RING SENSOR

Selection should be made based on the minimum hole diameter required. In this way the sensitivity adjustment can be made within normal parameters and need not be pushed to the maximum risking the proper functioning of the unit.

USE WITH A DELAYED AMPLIFIERS

All types of ring sensor can work in combination with a delayed amplifier of the programmable ALTP series which ensures the sensing of small objects in rapid movement.

SENSITIVITY ADJUSTMENT

After having followed the instructions regarding to the choice of the most suitable unit it is recommended that the sensitivity adjustment be carried out when the sensor is installed in the final position taking into account how much metal mass is close by which could alter its functioning. The sensitivity increases turning the trimmer clockwise and reduces by turning it anti-clockwise.

EFFECTS OF METAL IN THE CLOSE VICINITY

If a moving metal part is close to the sensing area the functioning can be disturbed. In order to avoid this, install the units some distance from metallic objects. Ensure that this does not interfere with the functioning.

USE OF SENSOR

A distance equal to the width of the sensor should be left between each object that passes through the sensor. If more than one sensor is to be installed in close vicinity, the minimum distance indicated between sensors should be observed.

MINIMUM DISTANCE BETWEEN SENSORS								
Type	SIA05	SIA12	SIA15	SIA22	SIA30	SIA44	SIA63	SIA100
A (Fig. 1) mm	25	30	30	60	60	300	300	600
B (Fig. 2) mm	10	10	10	20	20	250	250	650

Fig. 1

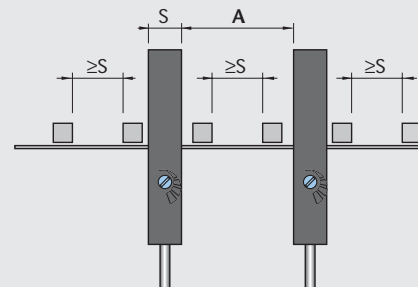
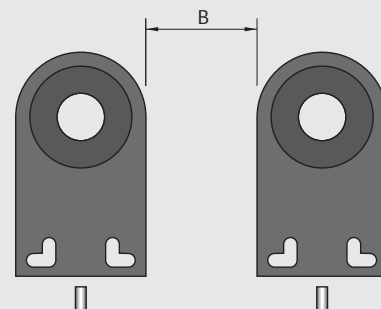

Fig. 2



Ring SIA

INDUCTIVE RING SENSORS

4 WIRED D.C.
CONFORMING TO EN 50025 - EN 50044
VERSION-C

ON/OFF SWITCH WITH DELAY
ON DE-ENERGIZATION 100ms.
ADJUSTABLE SENSITIVITY ON ALL MODELS



▲ EMBEDDABLE (FLUSH MOUNTING)

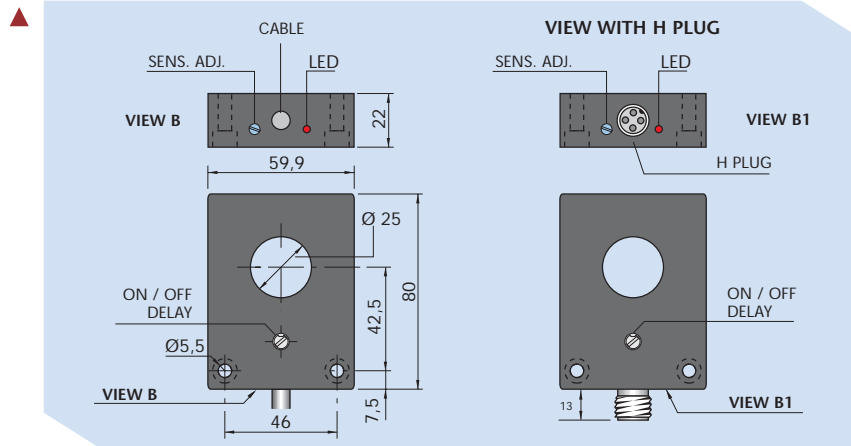

TECHNICAL CHARACTERISTICS

Dimensions mm

MODELS WITH CABLE	NPN	NO+NC	SIA25-C NPN NO+NC R
	PNP	NO+NC	SIA25-C PNP NO+NC R
MODELS WITH H PLUG	NPN	NO+NC	SIA25-C NPN NO+NC H R
	PNP	NO+NC	SIA25-C PNP NO+NC H R
Hole diameter Ø		mm	25
Continuous voltage (residual ripple ≤ 10%)		V	10 ÷ 30
Hysteresis		mm	In relation to Sn
Switching frequency		Hz	See table
Delay on de-energization		ms	100
Repeatability		mm	< 0.3
Max output current		mA	200
Absorption at 24 Vdc (sensor ON)		mA	< 15
Voltage drop (sensor ON)		V	< 1.8
Short circuit protection			Incorporated
Led			Incorporated
Temperature limits		°C	-20 ÷ +60
IP rating		IP	65
Housing			Plastic
PVC cable		2m	4 x 0.25 mm ²
Plug type			H

TYPE SIA25-C FLUSH MOUNTING

This inductive ring sensor has been created to solve shielding problems caused by other metallic elements.

It is well shielded against mutual interference created by other sensors installed close to each other.

For applications where these sensors have to be installed very close to each other let's say at less than 3 cm it will be necessary to order them with two different frequencies that we can call A and B. When installing these sensors types A and B must be placed in alternating positions.

WIRING DIAGRAMS

STANDARD MODEL - 4 WIRE CABLE

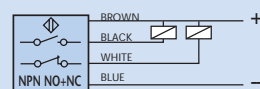

N.B.: Upon request cable for sensors with different lengths 3.5 - 5 - 7.5 - 10 metres is available.

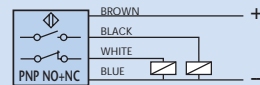

CONNECTION WITH H PLUG FOR THE CONNECTORS SEE PAGE 85

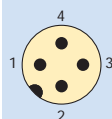

VIEW OF MALE CONNECTOR
1 = Brown / +
3 = Blue / -
4 = Black / output NPN-PNP / NO
2 = White / output PNP-PNP / NC

MIN. DIMENSIONS OF THE OBJECT TO DETECT Fe37

Model	SIA25	
Length	mm	7
Diameter	mm	4

SWITCHING FREQUENCY

The switching frequency of inductive ring sensors depends on delayed impulse time (when inserted) according to the formula:

$$\text{Switching frequency (Hz)} = \frac{1}{(T \text{ impulse} + 10) \text{ ms}}$$

Vice versa, the switching frequency will be between 600÷800 Hz.

Ring SIA

INDUCTIVE RING SENSORS



4 WIRED D.C.
CONFORMING TO EN 50025 - EN 50044
VERSION-C

● **NOT EMBEDDABLE**
(NON FLUSH MOUNTING)

● Ø D = 5-12-15-22-30

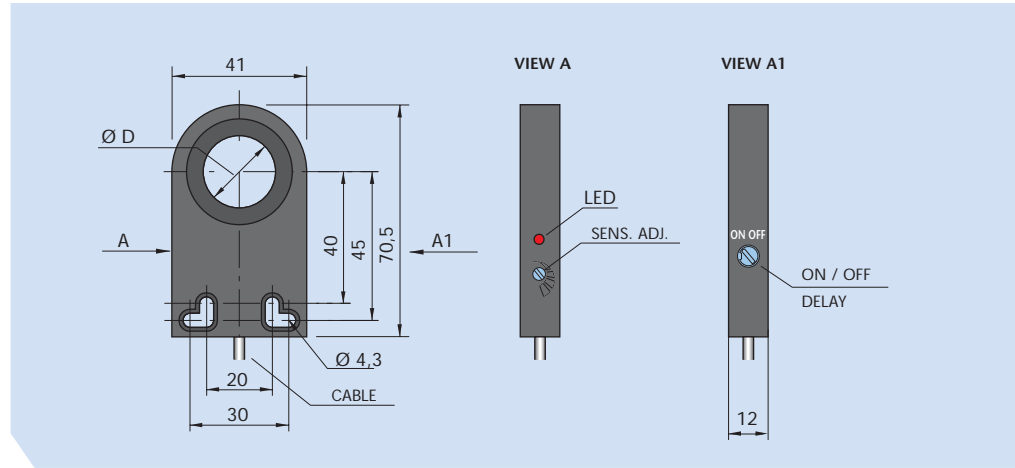

TECHNICAL CHARACTERISTICS

Dimensions mm

MODELS WITH CABLE	NPN	NO+NC	SIA05-CE NPN NO+NC R	SIA12-CE NPN NO+NC R	SIA15-CE NPN NO+NC R	SIA22-CE NPN NO+NC R
	PNP	NO+NC	SIA05-CE PNP NO+NC R	SIA12-CE PNP NO+NC R	SIA15-CE PNP NO+NC R	SIA22-CE PNP NO+NC R
MODELS WITH H PLUG	NPN	NO+NC	SIA05-CE NPN NO+NC H R	SIA12-CE NPN NO+NC H R	SIA15-CE NPN NO+NC H R	SIA22-CE NPN NO+NC H R
	PNP	NO+NC	SIA05-CE PNP NO+NC H R	SIA12-CE PNP NO+NC H R	SIA15-CE PNP NO+NC H R	SIA22-CE PNP NO+NC H R
Hole diameter Ø	mm		5	12	15	22
Continuous voltage (residual ripple ≤ 10%)	V		10 ÷ 30			
Hysteresis	mm		In relation to Sn			
Switching frequency	Hz		See table			
Delay on de-energization	ms		100			
Repeatability	mm		< 0.3			
Max output current	mA		200			
Absorption at 24 Vdc (sensor ON)	mA		< 15			
Voltage drop (sensor ON)	V		< 1.8			
Short circuit protection			Incorporated			
Led			Incorporated			
Temperature limits	°C		-20 ÷ +60			
IP rating	IP		65			
Housing			Plastic			
PVC cable	2m		4 x 0.25 mm ²			
Plug type			H			

WIRING DIAGRAMS

STANDARD MODEL - 4 WIRE CABLE

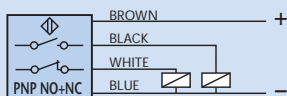
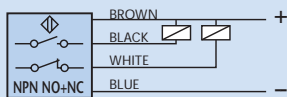

N.B.: Upon request cable for sensors with different lengths 3.5 - 5 - 7.5 - 10 metres is available.

CONNECTION WITH H1-H PLUGS FOR THE CONNECTORS SEE PAGE 85

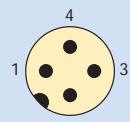

VIEW OF MALE CONNECTOR H
1 = Brown / +
3 = Blue / -
4 = Black / output NPN-PNP / NO
2 = White / output NPN-PNP / NC

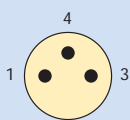

VIEW OF MALE CONNECTOR H1
1 = Brown / +
3 = Blue / -
4 = Black / output NPN-PNP / NO-NC

MODELS WITH H1 PLUG (M8)

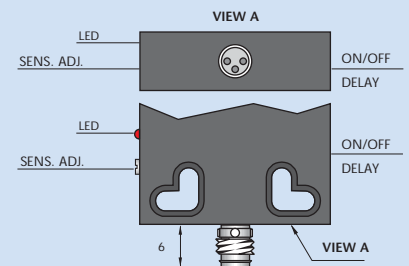

On request is available the H1 plug for SIA05-12-15-22 models. This versions can be supplied with NO or NC output only.

Ring SIA

INDUCTIVE RING SENSORS



ON/OFF SWITCH WITH DELAY ON DE-ENERGIZATION 100ms.
ADJUSTABLE SENSITIVITY ON ALL MODELS
MODELS WITH H PLUG FOR CONNECTOR

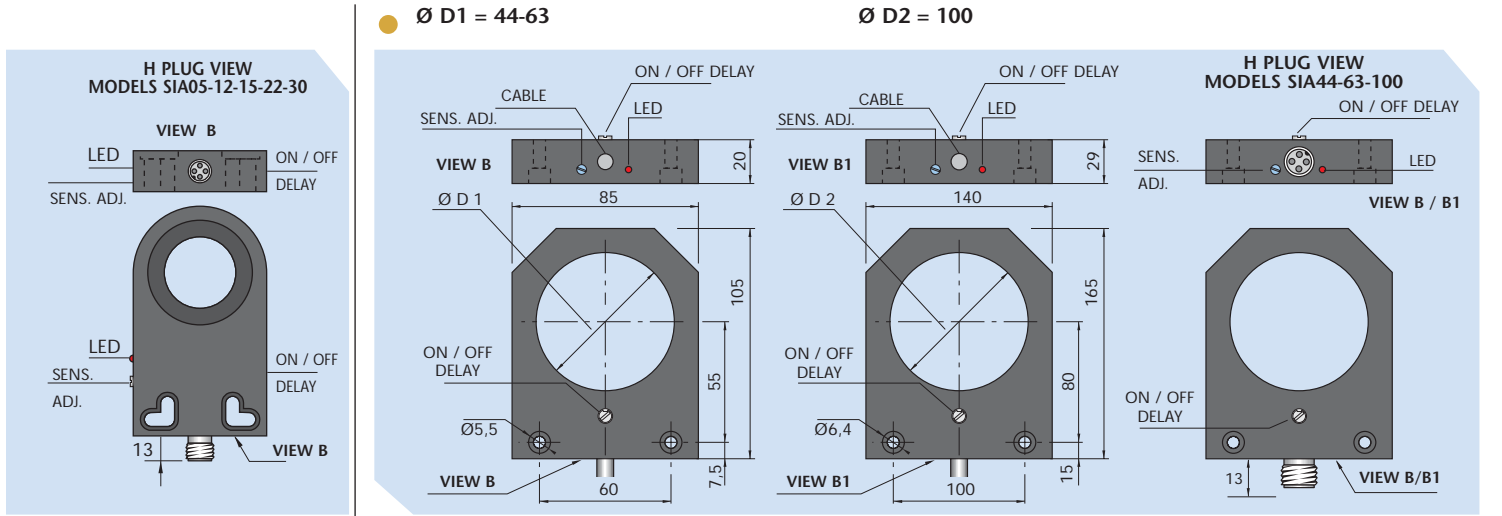

SIA30-CE NPN NO+NC R	SIA44-CE NPN NO+NC R	SIA63-CE NPN NO+NC R	SIA100-CE NPN NO+NC R
SIA30-CE PNP NO+NC R	SIA44-CE PNP NO+NC R	SIA63-CE PNP NO+NC R	SIA100-CE PNP NO+NC R
SIA30-CE NPN NO+NC H R	SIA44-CE NPN NO+NC H R	SIA63-CE NPN NO+NC H R	SIA100-CE NPN NO+NC H R
SIA30-CE PNP NO+NC H R	SIA44-CE PNP NO+NC H R	SIA63-CE PNP NO+NC H R	SIA100-CE PNP NO+NC H R
30	44	63	100

10 ÷ 30
In relation to Sn
See table
100
< 0.3
200
< 15
< 1.8
Incorporated
Incorporated
-20 ÷ +60
65
Plastic
4 x 0.25 mm ²
H

MIN. DIMENSION OF THE OBJECT TO DETECT Fe37

Models	SIA05	SIA12	SIA15	SIA22	SIA30	SIA44	SIA63	SIA100
Length mm	1	2	2	6	7	9	12	20
Diameter mm	0.7	1.2	1.2	3	4	5	6	12

SWITCHING FREQUENCY

The switching frequency of inductive ring sensors depends on delayed impulse time (**when inserted**) according to the formula:

$$\text{Switching frequency (Hz)} = \frac{1}{(T \text{ impulse} + 10) \text{ ms}}$$

Vice versa, switching frequency will be as per chart:

Models	SIA05	SIA12	SIA15	SIA22	SIA30	SIA44	SIA63	SIA100
Sw. Frequency Hz	600-1500	600-1000	600-1000	600-1000	600-800	250-600	100-200	100